

# OWNERS MANUAL

## **Sentry XL** SYNEXIS SYSTEM



# IMPORTANT SAFETY INSTRUCTIONS

BEFORE USING THIS DEVICE READ ALL INSTRUCTIONS AND CAUTIONARY STATEMENTS IN THIS MANUAL AND ON THE DEVICE.

The Sentry XL is an electrical device. Please read the safety instructions and considerations before use and take the necessary precautions to reduce the risk of fire, electric shock or injury. **The Limited Warranty applies only if the unit is used in accordance with these instructions.**

- ✓ Use the power cable provided with your device. The plug fits securely into a standard outlet. Do not alter the plug in any way.

**⚠ WARNING: Electrical shock can cause personal injury or death.**

**⚠ WARNING: Skin or eye damage may result from directly viewing the light produced by the lamp in this apparatus. Always disconnect power before relamping or servicing. Replace Lamp with Lamp Model No. E1008, manufactured by EMS.**

**⚠ WARNING: Do not allow the device to become clogged with dust or other debris. Check it regularly and replace the catalytic Sail or filter if they become clogged.**

**⚠ WARNING: To reduce the risk of fire or electric shock, do not use this product with any solid-state speed control device.**

When using an electrical device, basic precautions should always be observed, including the following:

## **⚠ WARNING**

**These warnings apply to the Synexis® device and, where applicable, to all tools and accessories TO REDUCE THE RISK OF FIRE, ELECTRIC SHOCK OR SERIOUS INJURY:**

1. Keep combustible materials, like bedding, clothing, curtains, furniture and paper at least three feet away from the device when it is plugged in.
2. Use only as described in this Synexis Operating Manual. Do not perform any maintenance other than what is shown in this manual. Any other use, not specifically recommended by the manufacturer may result in fire, electric shock or injury.
3. Make sure device is assembled by following manufacturer's instructions completely. Do not dismantle the device.

4. This Sentry XL device is not a toy. Use caution when children are nearby. Children should be kept away unless continuously supervised. Do not allow children to play with the Sentry XL device.
5. This Sentry XL device is not intended for use by persons (including children) with reduced physical or reasoning capabilities, or lack of experience and knowledge, unless they have been given supervision or instruction about the use of the Sentry XL device by a person responsible for their safety.
6. Sentry XL device is suitable for dry locations ONLY. DO NOT use outdoors, on or near wet surfaces. Do not use in bathrooms, laundry areas or similar indoor locations. Never place the Sentry XL device where it may fall into a bathtub or other water container. Do not use or store near a bath or shower, or a swimming pool.
7. Do not use the Sentry XL device in areas where fuel, paint, or flammable liquids are used or stored where their vapors are present.
8. Do not use in conjunction with or directly next to an air freshener or similar products.
9. Do not handle any part of the plug or Sentry XL device with wet hands.
10. UV light source. Disconnect power cord before servicing unit.
11. Do not sit on or place any object on this device.
12. Do not use with a damaged power cord or plug. If the power cord is damaged, it must be replaced by Synexis, its service agent, or similarly qualified persons in order to avoid a hazard.
13. Do not unplug the Sentry XL device by pulling on the power cord. To unplug, grasp the plug (not the cord), and remove from the power outlet.
14. Do not stretch the power cord or place the cord under strain. Keep the power cord away from heated surfaces.
15. Do not run the power cord underneath carpeting. Do not cover cord with throw rugs, runners or similar coverings. Do not route cord under furniture or other appliances. Avoid placing power cord in high-traffic areas or where it could be tripped over.
16. To prevent a possible fire, do not use with any opening or exhaust blocked, and keep free of dust, lint, hair, and anything that may reduce airflow. Do not put any object into the inlet grille or exhaust opening, as this may cause electric shock or fire, or damage to the Sentry XL device.
17. In order to avoid overheating, do not cover the Sentry XL device.
18. For the best performance, place the Sentry XL device where air intake and top grille are unobstructed.
19. Turn off all controls before unplugging. Always unplug Sentry XL device from the power outlet when it is not in use.

20. If the Sentry XL device is not working as it should, has been dropped, struck, damaged, left outdoors, or dropped into water, do not use and contact your Synexis Account Representative.
21. Contact Synexis when service or repair is required. Do not disassemble the Sentry XL device, as incorrect re-assembly may result in electric shock or fire.
22. Do not use any cleaning agents or lubricants on the Sentry XL device. Unplug power cord from outlet before performing any type of maintenance.
23. To avoid a tripping hazard, secure power cord when not in use.
24. Do not use Sentry XL device near furnaces, fireplaces, stoves or other high-temperature heat sources.
25. Do not spray or apply perfumes directly on or near the filter. Keep essential oils and chemicals away from the Sentry XL device.

## **READ AND SAVE THESE INSTRUCTIONS**

# Contents

Welcome.....	6
Included Parts.....	6
About Synexis® Dry Hydrogen Peroxide (DHP®) .....	7
Indications for Use .....	7
Legal Notice .....	7
System Specifications .....	8
Installation.....	9
Cleaning Instructions.....	13
Troubleshooting .....	13
Maintenance.....	13
Getting the Most from Your DHP™ System .....	14
Warranty .....	15



# Welcome

Thank you for choosing Synexis®, developers of Dry Hydrogen Peroxide (DHP®) and this Sentry XL device.

Before using the DHP system, please take a few minutes to:

- ✓ **Familiarize yourself with the Sentry XL device**
- ✓ **Familiarize yourself with the installation steps**
- ✓ **Inspect your system and parts**

Please contact your Synexis Account Representative for questions or additional information.

## Included Parts

- ✓ 1 Synexis® Sentry XL device
- ✓ 2 Custom UV-A LED Lamps (already installed)
- ✓ 1 Power Cord

## Starter Kit (Ships Separately)

- ✓ 2 Sails
- ✓ 2 Carbon filter
- ✓ 2 MERV 11 filters

## Optional Wall Mount Kit (Ships Separately)

- ✓ 1 Wall mount plate
- ✓ 2 Phillips head screws

After opening the box, unpack and inspect your device for damage.

**DO NOT OPERATE THIS DEVICE IF ANY DAMAGE IS NOTED.** If the device is damaged, contact your Synexis Account Representative.

# About Dry Hydrogen Peroxide (DHP®)

Synexis is the sole developer of hydrogen peroxide gas and Dry Hydrogen Peroxide (DHP) Technology for occupied spaces. Using DHP, our patented microbial reduction technology allows for the natural and continuous reduction of microbial contamination in occupied spaces. Synexis Microbial Reduction Systems are patented for use in the United States and around the world. By encompassing all areas of an enclosed space, DHP can reach the most important areas of a facility. The critical differentiator of DHP from other forms of hydrogen peroxide is that DHP™ can be safely delivered in occupied spaces.

Using ambient humidity and oxygen naturally present in your environment, Synexis technology creates a safe level of hydrogen peroxide (H<sub>2</sub>O<sub>2</sub>) gas, which reduces unwanted microbial contamination in the air and on surfaces. Because DHP™ is a true gas, it can reach the toughest and most out-of-reach areas of your facility. Dry Hydrogen Peroxide is effective because of its state of matter and method of action.

## Indications for Use

This product is not sold as a medical device and is not intended to be used to diagnose any disease or condition, nor should it be used in the mitigation, treatment, or prevention of any disease or condition. The Sentry XL device is a key component of the Synexis Microbial Reduction System.

## Legal Notice

While every attempt is made to ensure the accuracy of the information contained in this manual, Synexis accepts no liability for errors or omissions, or any consequences deriving from the use of information contained herein. This Sentry XL manual is provided “as is” and without any representation, term, condition or warranty of any kind, either express or implied. To the extent permitted by law, Synexis shall not be liable to any person or entity for any loss or damage which may arise from the use of this manual. We reserve the right at any time and without any notice to remove, amend or vary any of the content which appears herein.



Your Synexis® Sentry XL  
DHP™ System is  
Assembled in the USA!

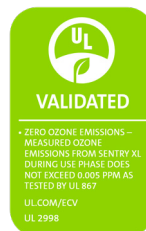

# Sentry XL

## System Specifications

The Sentry XL is a portable device designed for deployment in industrial facilities. The Sentry XL has a rugged plastic and metal design for the most challenging environments. The Sentry XL can be mounted virtually anywhere and requires only a standard 120V–50/60 Hz (North America) outlet.

Specifications	
<b>Weight</b>	25 lbs.
<b>Material</b>	Polycarbonate, stainless steel, and aluminum
<b>Color</b>	White
<b>Mounting Options</b>	Floor (Shown), Wall Mount
<b>Dimensions</b>	Depth: 10.5" (266 mm) Height: 21.5" (546 mm) Width: 19.5" (493 mm)

Electrical Requirements	
<b>Input Voltage</b>	120 VAC–50/60 Hz US
<b>Current</b>	1.30 Amps US

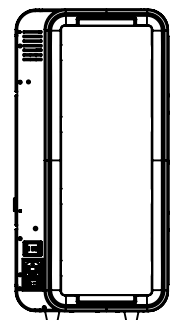
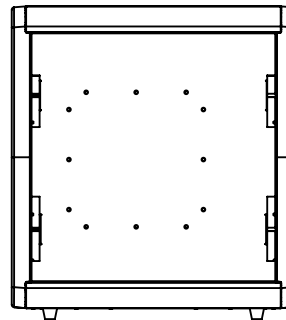
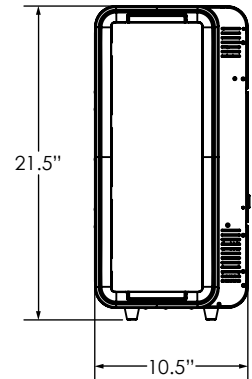
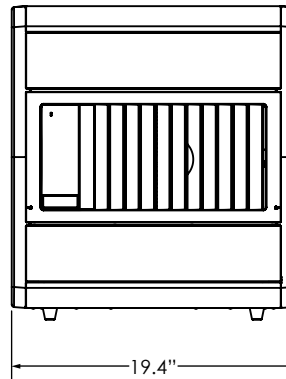
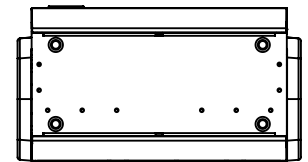
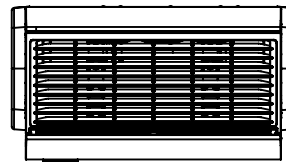
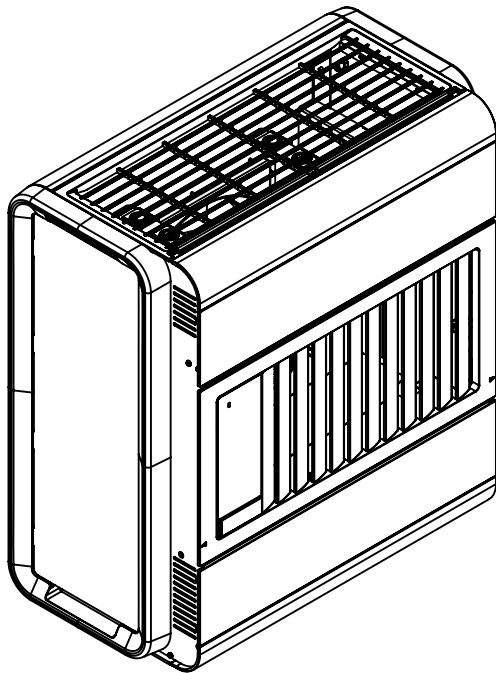



# Installation

1. To Insert the Sail, lift up the top curved panel on the front and rotate the white latch 90 degrees clockwise. Insert Sail into horizontal slot and re-secure the latch and close the panel.



## Installation (cont.)

2. Open louvered panel below that and rotate the white retention latches. Insert carbon filter first, then place MERV 11 filter on top of that, with airflow arrows pointing toward the device.



## Installation (cont.)

3. Re-secure white retention clips and close access panel.



4. Plug in and power the device on.



## Installation (cont.)

5. The UV-A lamps will begin to glow. At any point, to turn the bulbs off, turn the power switch off.



6. To adjust device airflow, use the 3-way switch on the side panel.



# Troubleshooting

If the fan does not operate, contact your Synexis Account Representative at 844-352-7680 for assistance.

## Maintenance

To keep your device(s) in top condition, we recommend routine cleaning. *If your purchase of the Synexis Microbial Reduction System includes a maintenance contract, the following recommendations are handled by Synexis Field Engineers during regular scheduled visits.*

- **Filter Cartridge and Sail Replacement:** Filter cartridges and Sails are replaced using the typical schedule below. Each Sail comes pre-packaged in a food-grade plastic bag to maintain quality before use. For best performance, the Sail should not be removed from the bag until it is time to insert it into the device. The filters and Sail can be disposed of in regular trash or as recyclable fiber and plastic (frame and polyester fabric). No special handling conditions are required.

### Sail Replacement

- Every 6 months\*

### Filter Replacement

- **MERV 11 filter:**
  - Every 6 months\*\*
- **Carbon Filter:**
  - Every 6 months\*\*

Do not try to repair or adjust any of the electrical components in your Sentry XL device. Contact Synexis for assistance.

*\* Complex environments might require a more frequent Sail change. This is identified on the front-end of a project and would be detailed in the agreement.*

*\*\* Complex environments (such as industrial applications) involve higher levels of particulates in the air. Under such conditions, filters may need to be changed on an 'as-needed basis'.*

## Cleaning Instructions

**Always disconnect the device from electrical power source prior to cleaning/disinfecting.**

In typical use environments with no disinfectant requirements periodically use a vacuum to remove dust collected around the air inlet and a cloth damp with water to wipe down external features of device.

For environments that require regular disinfecting of the external features of the device, replace the damp cloth with an EPA registered disinfectant wipe that has hydrogen peroxide as the active ingredient. Apply disinfectant according to manufacturer's use instructions and ensure that no liquid from the wipe drips through the vents onto the catalyst coated sail. If there is a possibility of the cleanser dripping on the sail, replace the sail and continue the use of the device.

# Getting the most from your DHP® System

It is important to work with your Synexis Account Representative to determine the proper number of units for the size and configuration of your space. In some cases, multiple Synexis devices will be necessary. Be sure to change the Sail according to the recommended replacement schedule. Leave unopened Sails in their plastic bag and store them in a dark, dry location until you need to replace the current Sail in your device.

## Close your windows and outside doors

The Sentry XL is designed for enclosed space, so it is important to keep all external windows and doors closed as much as possible. Open windows and/or doors can significantly reduce the efficiency of your system by allowing the DHP to dissipate out of the facility.

## Run your Synexis System 24 hours a day

The Sentry XL is designed to operate 24 hours a day, 7 days a week. DHP is meant to be a continuous clean technology as opposed to a temporary clean technology. The DHP molecule is delicate and safe at low concentration. Producing it continuously ensures a proper equilibrium concentration in your space for effective decontamination. Visit [Synexis.com](http://Synexis.com) for more information.

# 1-Year Limited Warranty

Contact your Synexis Account Representative for any device questions, service material needs or device issues. When contacting Synexis for a system issue that is under warranty, please be prepared to provide the following:

- ✓ A copy of the bill of sale
- ✓ Invoice or receipt of purchase
- ✓ An explanation of the problem or defect



**synexis**<sup>®</sup>

**Synexis<sup>®</sup> LLC**  
11711 W. 79th Street  
Lenexa, KS 66214  
+1 (844) 352-7680  
[info@synexis.com](mailto:info@synexis.com)